

## So You Need to Measure Some Inductors...

Take a look at the 1910 Inductance Analyzer. Although specifically designed for production testing of inductors and coils, in addition to measuring inductance (L), the 1910 instrument is capable of measuring C, D<sub>F</sub>, Q, Y, G, B, Z, R, X, ESR,  $\theta$ , DCR as well as the AC & DC voltage and current to the DUT. It has a wide frequency range (20Hz to 1MHz), 0.1% basic measurement accuracy, 4-terminal Kelvin connections, and remote interface capability (IEEE-488, RS232, Handler) all included with the standard unit. The 1910 unit can be programmed for internal DC Bias current ranging from 1mA – 1.0A in 1mA steps. It also offers a host of other unique features including sequential testing, voltage leveling, load correction, programmable source impedance and built in automatic calibration.

Recent advances in switching power supplies and the telecommunications industry have resulted in requirements for inductors with high frequency characteristics and low loss. In this light, the testing of inductors is also moving to higher frequencies. Let's take a look at inductor measurements in general and some application specific features of the 1910 that illustrate its full potential in characterizing passive components.

There are a number of parameters that characterize an inductor. The most commonly measured parameters are inductance (L) and quality factor (Q). In addition DC resistance (DCR) can also be a useful parameter as well. In this article we will discuss each of these parameters as well as typical issues that can arise when measuring each parameter.

### Inductance

Inductance is a basic electrical property of any coil. The unit of inductance is the Henry. The inductance of a coil depends on the number of turns, diameter of the coils, the length of the coil and the nature of the core. By definition the inductance is the ratio of the total magnetic flux linkage ( $\Lambda$ ) to the current (I) through the inductor or coil. A mouthful but the main point is that total magnetic flux linkage is dependant upon permeability ( $\mu$ ) of the medium (core material). This means inductance is directly proportional to permeability. Most inductance standards have an air or non-magnetic core making their induction characteristics predictable since the permeability of air is constant. Permeability however is not a constant for ferrous media and herein lies the problem. Permeability varies based upon the material and the flux density.  $\langle L = \Lambda / I = \mu N^2 r^2 / 2R \rangle$ . The material does not change but the flux density varies based upon the amount of current flowing through the coil. Figure 1 illustrates the inductance formulas for a toroid and a coaxial cable.

# Toroid & Cable Inductance Formulas

## Toroid

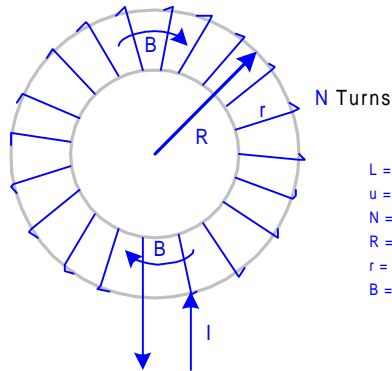

L = inductance of toroid  
 u = permeability of coil medium  
 N = number of turns of toroid  
 R = radius of toroid  
 r = radius of coil  
 B = flux density

## Inductance of Toroid

$$L = \frac{\Lambda}{I} = \frac{uN^2r^2}{2R}$$

## Coaxial Cable

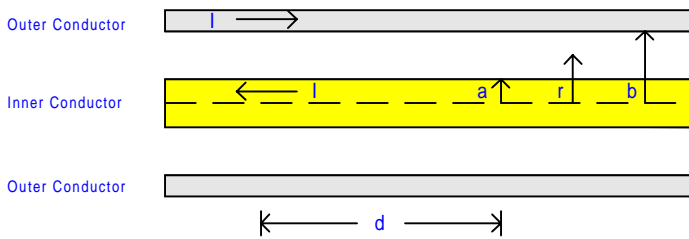

Longitudinal Section

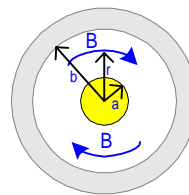

Cross Section

## Inductance of Length of Cable

$$L = \frac{\Lambda}{I} = \frac{ud \ln(b/a)}{2\pi}$$

**Figure 1: Toroid & Cable Inductance Formulas**

Okay so what does this all mean? In order to get an accurate inductance measurement the inductor must be tested under actual conditions for current flowing through the coil. This cannot always be done with the typical AC source and a standard LCR meter as the typical source in an LCR meter is normally only capable of supplying small amounts of current. This level of current is not satisfactory for testing most inductors used in power supplies. Rather than using a larger AC current source, inductors are usually tested with a combination of DC current and AC current. **DC bias current** provides a way of biasing the inductor to normal operating conditions where the inductance can be measured with a normal LCR meter. One of the benefits of the 1910 inductance analyzer is its ability to internally generate between **1mA and 1 A of DC bias current** without the use of any external bias source.

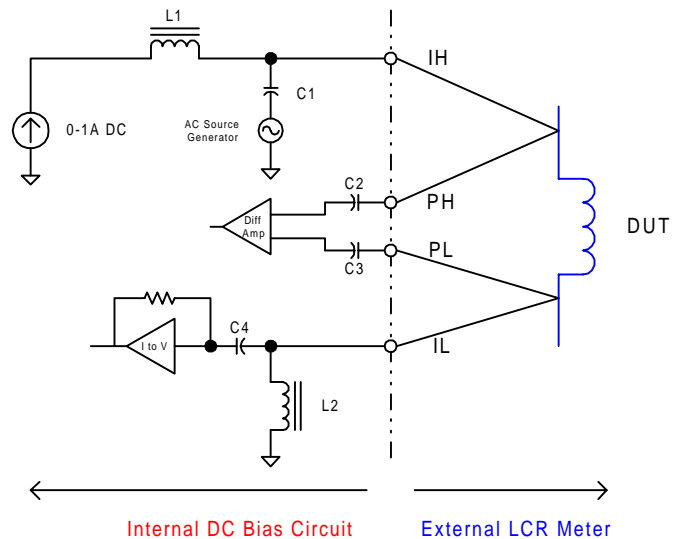

**Figure 2: 1910 Internal DC Bias**

## Inductors are all about Current

The bottom line of all this is that the measured inductance is dependent on the **current** flowing through the inductor.

### DCR Measurements

The 1910 instrument is capable of measuring DC Resistance over the range of  $1\text{m}\Omega$  -  $100\text{k}\Omega$ . Measuring the DCR or winding resistance of a coil of wire confirms that the correct gauge of wire, tension and connection were used during the manufacturing process. The amount of opposition or reactance a wire has is directly proportional to the frequency of the current variation. That is why DC resistance is measured rather than ACR. At low frequencies, the DC resistance of the winding is equivalent to the copper loss of the wire. Knowing a value of the wire's copper loss can provide a more accurate evaluation of the total loss ( $D_F$ ) of the device under test (DUT).

### Constant Source Impedance

The other concern is that the **current** flowing through the inductor from the AC source in the LCR meter must be **held constant**. If the current is not held constant the inductance measurements will change. This change is generally a function of the LCR meter's open circuit programmed test voltage. The programmed voltage in an LCR meter is obtained under an open circuit condition. A source resistance ( $R_s$ , internal to the meter) is effectively connected in series with the AC output and there is a voltage drop across this resistor. When a test device is connected, the voltage applied to the device depends on the value of the source resistor ( $R_s$ ) and the impedance value of the device. The source impedance is normally between  $5\Omega$  to  $100\text{k}\Omega$ . The effect of source resistance is illustrated in Figure 3. The programmed voltage is  $1\text{V}$  but the voltage to the test device is  $0.5\text{V}$ , which means that the voltage across the DUT is **always less** than the programmed voltage.

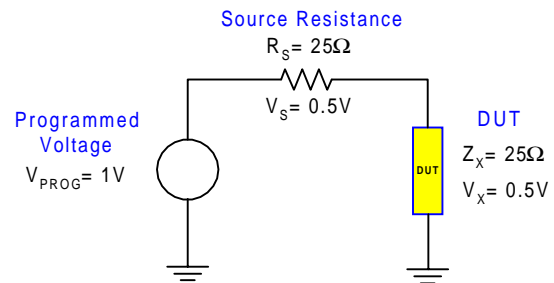

**Figure 3: Constant Source Resistance**

Since the voltage across the inductor changes with impedance of the inductor and the impedance of the inductor changes with current, a typical LCR meter designed for measurements on capacitive and resistive devices can cause the inductance to appear to drift. The actual inductance is not drifting but is caused by the voltage across the inductor **not being constant** so the current is not constant. The 1910 Inductance Analyzer provides a **voltage leveling** circuit to minimize this problem of inductance drifting. The voltage leveling circuit monitors the voltage across the inductor and continually adjusts the programmed source voltage in order to **keep the voltage across the inductor constant**.

## Q & D Indicate Inductor Loss

Quality Factor (Q) is another important characteristic of an inductor. The Q is the ratio of Reactance to Resistance and therefore is unit less. The higher the Q of an inductor the fewer losses there are in the inductor. The Dissipation Factor (D) can be referred to as the total loss within a component and is defined as  $1/Q$ . The total loss (D) of a coil is comprised of Copper Loss, Eddy-Current Loss and Hysteretic Loss.

Copper Loss at low frequencies is equivalent to the DC resistance of the winding. Copper loss is inversely proportional to frequency. Which means as frequency increases, the copper loss decreases. Copper loss is typically measured using an inductance analyzer with DC resistance (DCR) measurement capability rather than an AC signal.

Eddy-Current Loss in iron and copper are due to currents flowing within the copper or core caused by induction. The result of eddy-currents is a loss due to heating within the inductors copper or core. Eddy-current losses are directly proportional to frequency.

Hysteretic Loss is proportional to the area enclosed by the hysteresis loop and to the rate at which this loop is transversed (frequency). It is a function of signal level and increases with frequency. Hysteretic loss is however independent of frequency.

The dependence upon signal level does mean that for accurate measurements it is important to measure at known signal levels. And signal levels are dependent upon frequency.

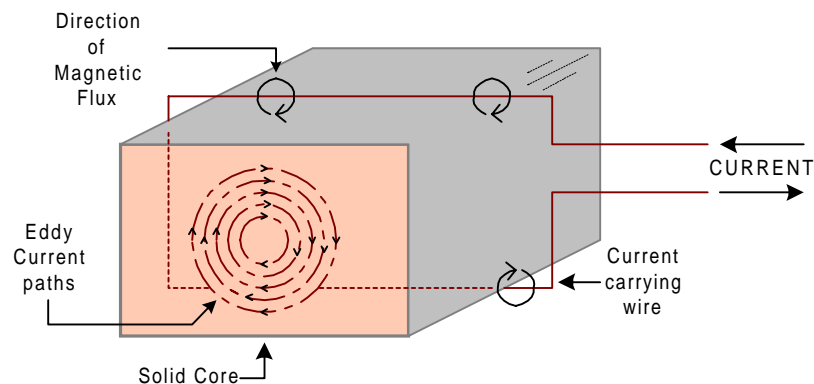

**Figure 4: Eddy Currents induced in a solid iron core**

Construction of the inductor is paramount to its end use. The symmetry of a toroid inductor provides good stability and a constant temperature coefficient. An air core in an inductor results in the highest stability and a negligible variation of inductance with current at the expense of a relatively low Q. Iron cores have a higher permeability and for a given volume can provide a larger inductance and a larger Q. However, the permeability of ferromagnetic materials can change with age and particularly with current making the iron core inductor less stable than the air core inductor. Proper design and selection of the core material will yield a more stable and precise inductor.

## Inductor Example

The Dissipation Factor versus Frequency graph in Figure 5 illustrates the dielectric loss in 1482 Inductor. The 1482-L Inductance Standard was designed with an air core for high stability because its primary use is as a laboratory calibration standard. The core adds three more components to the dissipation factor: one from eddy currents in the core (proportional to frequency), another from hysteresis loss in the core (independent of frequency) and a third from residual losses in the core (constant with frequency and relatively small).



1482 L Inductor

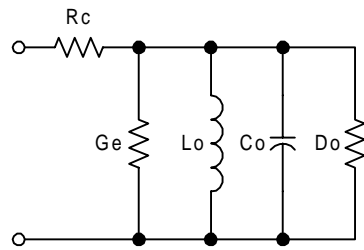

Equivalent Circuit: Air Core Inductor

- Rc = Series Resistance
- Ge = Conductance due to eddy current loss
- Do = Dissipation factor of the distributed capacitance
- Co = Shunt capacitance of terminal windings
- Lo = Zero frequency inductance
- f = Frequency
- fr = Resonance Frequency

$$D \approx \frac{1}{1 - \left(\frac{f}{f_r}\right)^2} \left[ \frac{R_o}{\omega L_o} + G_e \omega L_o + \left(\frac{f}{f_r}\right)^2 D_o \right]$$

Resonance Factor
 $D_o$  Ohmic Loss
 $D_e$  Eddy Current Loss
 $D_d$  Dielectric Loss

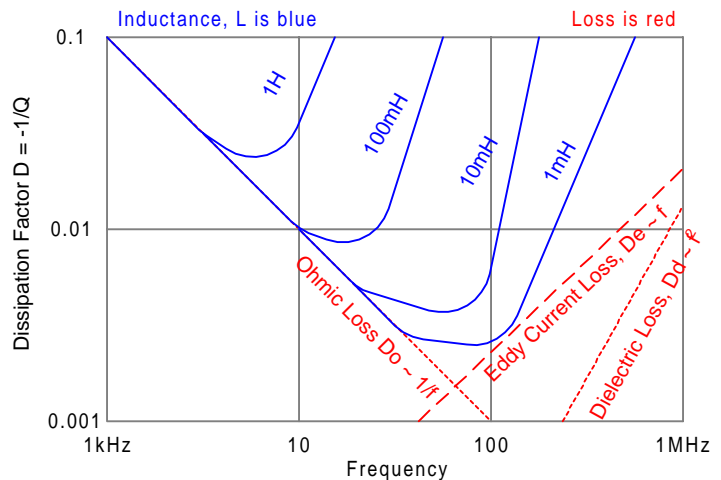

**Figure 5: 1482 Inductance Standard Loss Curve**

For complete product specifications on the 1910 Inductance Analyzer or any of QuadTech's products, please visit us at <http://www.quadtech.com>. Call 1-800-253-1230 or email your questions to [info@quadtech.com](mailto:info@quadtech.com).

The information presented here is subject to change and is intended for general information only

©QuadTech, Incorporated

Telephone: 1-800-253-1230, Website: <http://www.quadtech.com>

Printed in U.S.A.

PN 035083/A2

July 2003